

The Donaldson TopSpin™ Pre-Cleaner Can Maximize Your Intake System



Donaldson TopSpin™ will extend primary air filter life, boost system efficiency and extend engine life!

Donaldson TopSpin requires no maintenance and works great on all types of equipment, from crawler tractors to farm tractors to skid steer loaders.

Donaldson®

Donaldson TopSpin Extends the Life of Your Air Filter

If your vehicle already has a pre-cleaner, you obviously recognize its importance. A pre-cleaner will extend your air filter's life, reducing your filter and overall operating costs. Donaldson TopSpin will separate a greater amount of debris and contaminant compared to competitive products.

Separates up to 85% of incoming contaminant (per ISO 5011/SAE J726)

- Greatly extends air filter life
- Reduces air filter usage
- Lowers cost per operating hour
- Automatically ejects mixed debris
- Separates more than 99% of particles 20 micron and larger

Operates at a lower RPM

- Less noise
- Longer bearing life
- Lower restriction

Self-cleaning/self-scavenging

- No maintenance to clean bowl
- No exhaust ejector required

Easy installation

- Quick installation
- One clamp to tighten
- No wires or power requirements

Dual mounted bearings

- More robust design
- Extends bearing life

Lighter Weight

- Lighter than competitive pre-cleaners
- Lighter than Donaldson full-view pre-cleaner

How it Works!

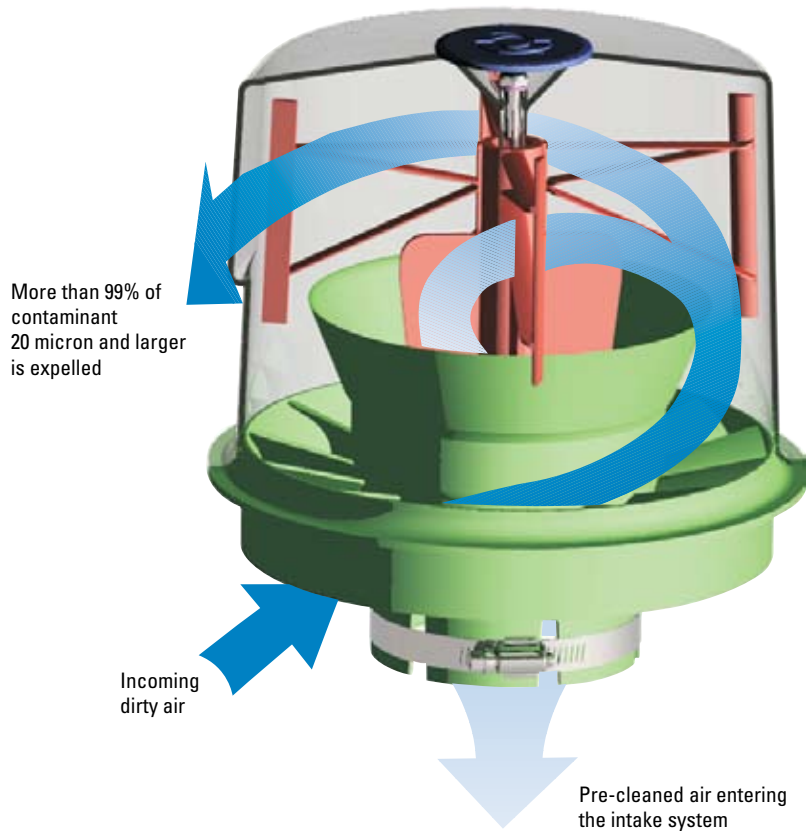

TopSpin™ products are protected internationally by patents, trademarks, and design registrations, both issued and pending.



The aerodynamically designed TopSpin™ is made of a lightweight, durable, non-corroding material which makes it tolerant to all weather and operating conditions.

During the product development process, Donaldson engineers used sophisticated flow analysis tools (Fluent CFD) to predict and simulate real-life flow conditions. Flow direction, velocity ranges, recirculation zone identification, and particle tracking and efficiency can be predicted with this analytical tool.

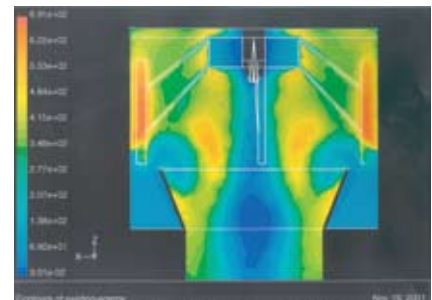

This CFD image was taken during the development process of Donaldson TopSpin.

Performance Curves

The Donaldson TopSpin pre-cleaner has the lowest restriction of any competitive brands tested, including our own full-view pre-cleaner.

Multiple tests conducted per ISO 5011/SAE J726 and average results are shown in charts below.

Lower restriction means:

- Your engine “breathes” easier
- You can reduce air filter usage
- You will have lower costs per operating hour
- More dust loaded on the filter when serviced by restriction

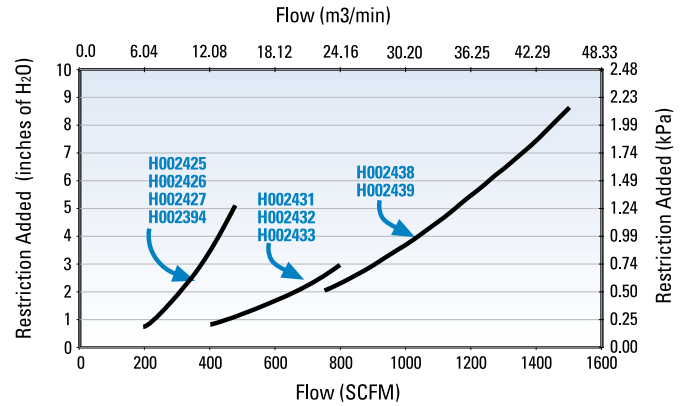
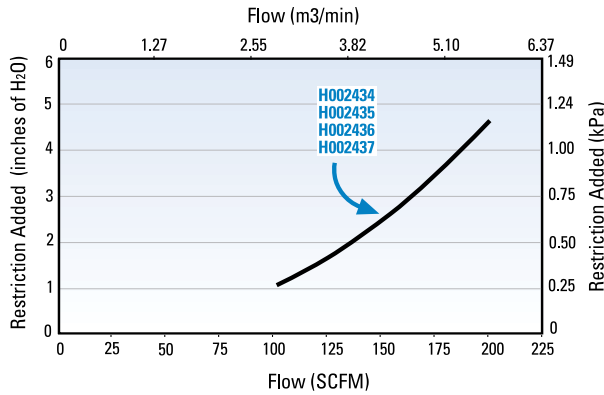

Dimensional Specifications

Donaldson TopSpin can be mounted horizontally or vertically. Installation instructions, stainless clamp and warranty are included.

Outlet I.D. (C)		Overall Height (A)		Body Dia. (B)		Part Number	Operating Flow Range		Weight	
in.	mm	in.	mm	in.	mm		CFM	m3/min	lbs.	kg.
2.03	56	5.75	146	6.38	162	H002434	90-200	2.5-5.7	1.0	0.4
2.27	58	5.75	146	6.38	162	H002435	90-200	2.5-5.7	1.0	0.4
2.53	64	5.75	146	6.38	162	H002436	90-200	2.5-5.7	1.0	0.4
3.03	77	5.75	146	6.38	162	H002437	90-200	2.5-5.7	1.0	0.4
3.07	78	9.39	238	9.51	242	H002425	200-450	5.7-12.7	2.2	1.0
3.83	97	9.39	238	9.51	242	H002426	200-450	5.7-12.7	2.2	1.0
4.06	103	9.39	238	9.51	242	H002394	200-450	5.7-12.7	2.2	1.0
		11.30	287	11.32	288	H002431	450-750	12.7-21.2	2.7	1.2
4.56	116	9.39	238	9.51	242	H002427	200-450	5.7-12.7	2.2	1.0
		11.30	287	11.32	288	H002432	450-750	12.7-21.2	2.7	1.2
5.03	128	11.30	287	11.32	288	H002433	450-750	12.7-21.2	2.7	1.2
6.03	153	13.57	345	15.62	397	H002438	750-1500	21.2-42.5	6.0	2.7
7.03	179	13.57	345	15.62	397	H002439	750-1500	21.2-42.5	6.0	2.7

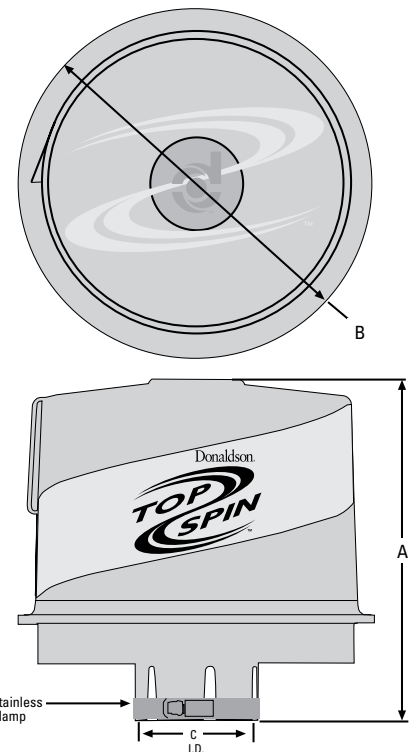

SCFM = Standard Cubic Feet per Minute. The ISO 5011/SAEJ726 test procedure was used to extract the results in the charts above. The ISO 5011/SAEJ726 is a widely accepted industry test used by OEMs to evaluate the efficiency of the intake system components. Test results are an average from testing several units.

Eliminate Bowl Dumping!

If your equipment has one of Donaldson's original full-view pre-cleaners, switching to a TopSpin Pre-Cleaner can eliminate the routine task of emptying the bowl.



Donaldson Full-View
Pre-Cleaners

Full-View Pre-Cleaner	TopSpin™ Pre-Cleaner
H000820	H002425
H000821	H002426
H000858	H002394
H000823	H002427
H001250	H002435
H001251	H002436
H001249	H002437
H001823	H002434
H002043	H002433
H002044	H002432
H002045	H002431
H002223	H002438
H002224	H002439