

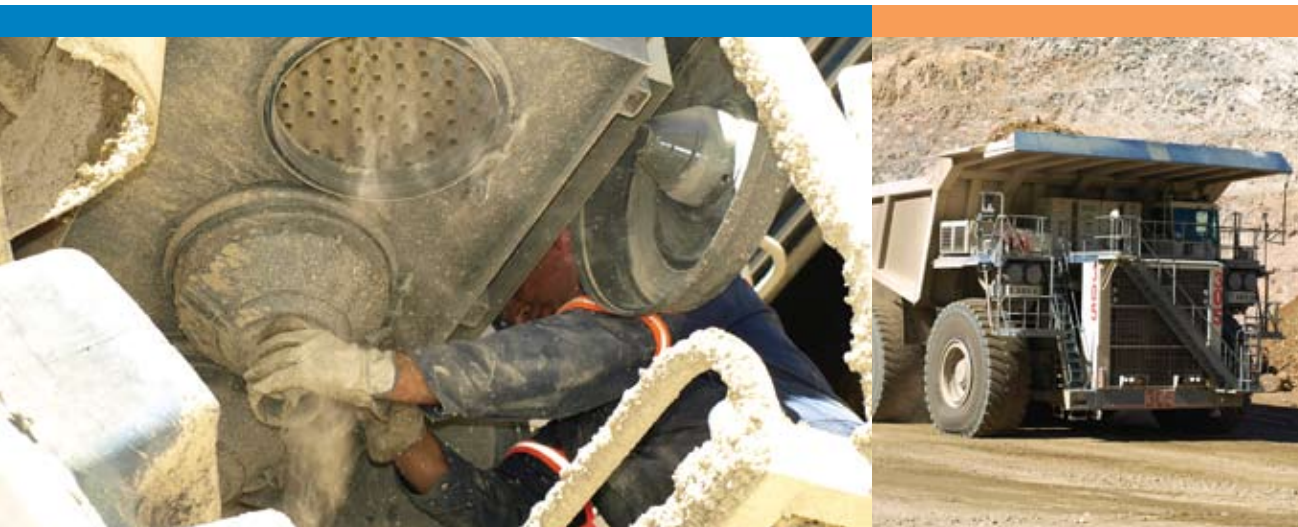

The SSG Air Cleaner for Mega Machines that Operate in Heavy and Severe Dust Conditions



These air cleaners are designed for the worst dust conditions.

- Single and dual outlet models - two high-flow models available
- Inlet has perforated holes on three sides, rain shrouds available if required
- Filters are urethane end caps with radial seal sealing technology
- Built-in pre-cleaning tubes that separate up to 95-97% of the in-coming dust
- Available with standard cellulose media or Ultra-Web® nanofiber technology
- Latch-style cover with attached safety chain for faster and simpler filter service
- Constructed of heavy-gauge steel with a primed, ready-to-paint finish
- Same overall package size as older Donaldson SRG axial seal style housings
-  Drop Down Tube Extensions for Dust-Cups

Design Improvements

enhance Serviceability

... simpler service and reliable filtration performance in one package!

Design Features

Radial seal filters slip easily on and off the outlet tube during service and installation. Metal endcaps have been replaced with durable, one-piece, urethane molded endcaps.



The SSG has simplified filter service with the quick release cover latches and a chain that is permanently connected to the housing and cover.



The SSG inlet section has a bank of Donaclone® pre-cleaning tubes that separate 95-97% of the heavier dust particles from the air stream. The pre-cleaned particles fall into the dust cups and the partially cleaned air is directed upward, into the primary filter.



Dual Outlet Model

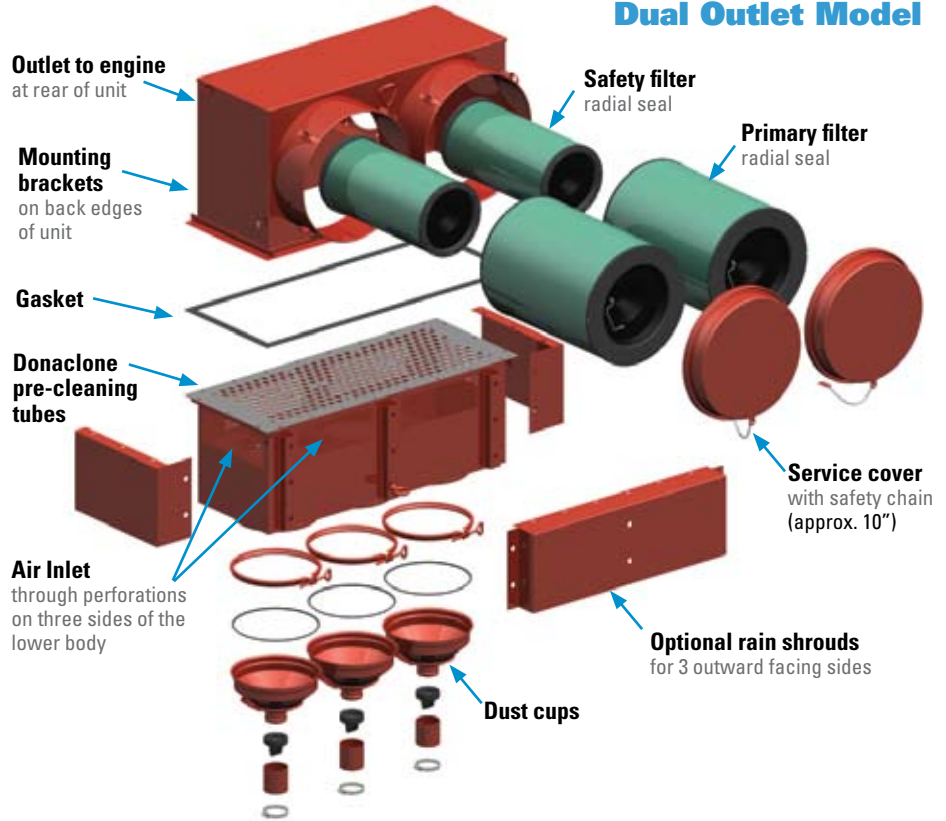

Single Outlet Model

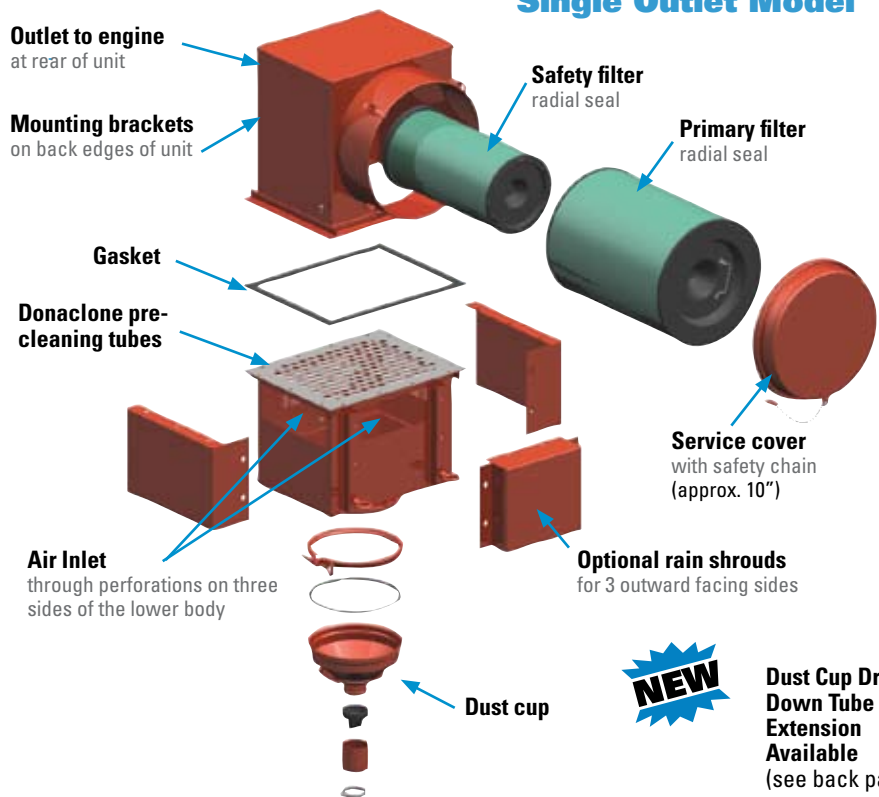

NEW

Dust Cup Drop Down Tube Extension Available (see back page)



Mining Haul Truck outfitted with two Donaldson SSG Air Cleaners

When spec'ing an Air Cleaner . . .

Determine the airflow requirements of your engine, then find the corresponding cfm airflow in the table at right. The restriction numbers (shown in inches of water) indicate the approximate initial restriction of each model air cleaner at that cfm. If there are two air cleaner models that fit your parameters, choosing the one with the lowest restriction will provide longest filter service life. When calculating total initial restriction of the entire air intake system, include the restriction caused by ducting and elbows.

Initial Airflow Restriction

CFM @		Air Cleaner Model
6" H ₂ O	8" H ₂ O	
SINGLE OUTLET MODELS		
1,700	1,980	G200087
1,780	2,060	G200086
2,100	2,400	G200088*
DUAL OUTLET MODELS		
2,580	3,000	G290057
3,340	3,800	G290052
3,600	4,080	G290053
4,200	4,800	G290055*

* Sized to accommodate higher airflow.

SSG Air Cleaner Specifications

Air Cleaner Models	Body Diameter (A)		Outlet Diameter (C)		Length (D)		Outlet Length (F)		Height (H)		Service Clearance (I)		Width (J)		Depth (K)		Weight		
	in	mm	in	mm	in	mm	in	mm	in	mm	in	mm	in	mm	in	mm	lbs	kg	
SINGLE OUTLET MODELS																			
G200087	19.67	500	8.0	203	26.2	665	3	76	50.15	1,274	22.0	559	21.00	533	15.75	400	200	91	
G200086	19.67	500	10.0	254	26.2	665	3	76	50.15	1,274	22.0	559	21.00	533	15.75	400	200	91	
G200088	19.67	500	10.0	254	31.4	798	3	76	50.15	1,274	27.0	686	21.00	533	23.50	597	240	109	
DUAL OUTLET MODELS																			
G290057	19.67	500	8.0	203	26.2	665	3	76	49.42	1,255	22.0	559	43.00	1,092	15.75	400	340	154	
G290052	19.67	500	8.0	203	26.2	665	3	76	49.42	1,255	22.0	559	43.00	1,092	15.75	400	340	154	
G290053	19.67	500	10.0	254	26.2	665	3	76	49.42	1,255	22.0	559	43.00	1,092	15.75	400	340	154	
G290055	19.67	500	10.0	254	31.4	798	3	76	49.42	1,255	27.0	686	43.00	1,092	23.50	597	420	190	

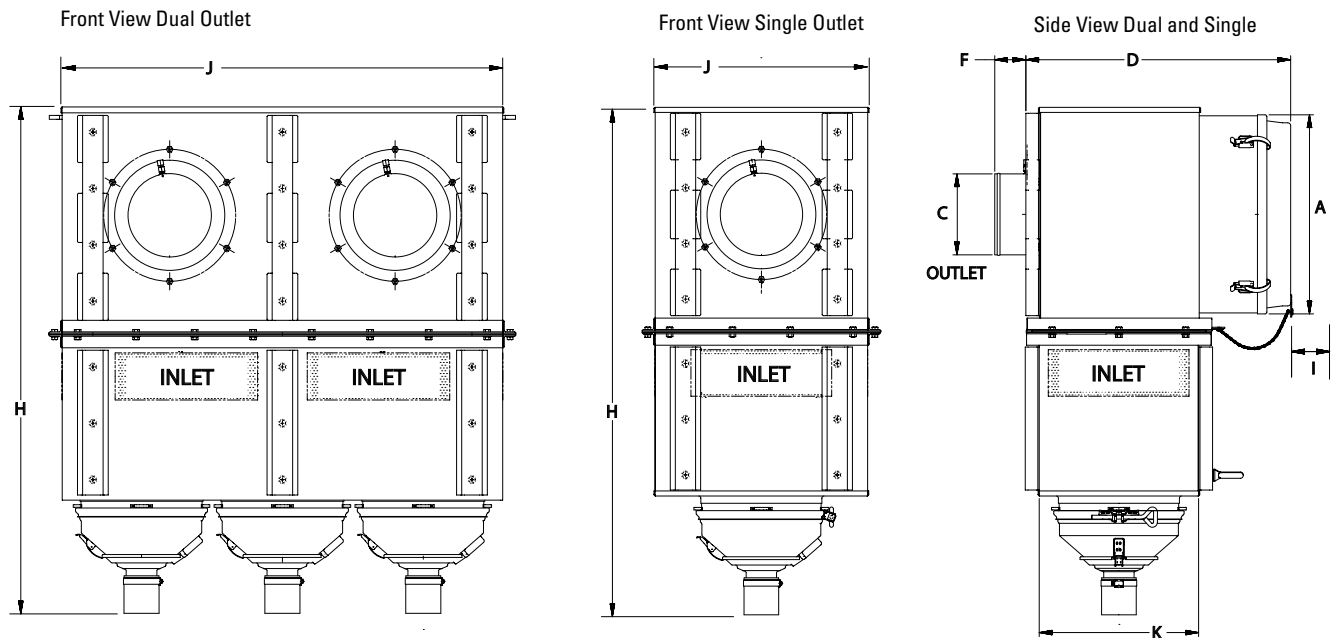

Covered by issued and pending patents, both U.S. and internationally

Dust Cup Drop Down Tube Extension

How it works: When installed on the dust cups on the lower assembly, the rubber connector vibrates during normal vehicle operation and gravity expels the pre-cleaned dust.



- Improves dust evacuation from the air cleaner
- Clear tube allows for visual inspection of dust collection
- Reduces air cleaner inspection time
- Ships fully assembled
- Proper conversion requires drop down tube for every dust cup



Part No. X006561

Service Parts Listing by Model Number

G200086, G200087

cover	P603716
cover chain	P017281
chain connector	P017283
dust cup	P158089
dust cup gasket.....	P017804
dust cup clamp.....	P100808
dust cup vacuator valve.....	P103198
body gasket strips (two, short)	P115098
body gasket strips (two, long).....	P117791
rain shroud, right side	P119874
rain shroud, front	P119876
rain shroud, left side.....	P119875
lower body assembly.....	P117785
filter, primary radial seal.....	P608306*
filter, primary extended life.....	EAF5152
filter, safety radial seal.....	P608305*

G200088 (longer upper unit)

cover	P603716
cover chain	P017281
chain connector	P017283
dust cup	P158089
dust cup gasket.....	P017804
dust cup clamp.....	P100808
dust cup vacuator valve.....	P103198
body gasket strips (two, short)	P603504
body gasket strips (two, long).....	P117791
rain shroud, right side	P610776
rain shroud, front	P119876
rain shroud, left side.....	P610777
lower body assembly.....	P603505
filter, primary radial seal.....	P609519*
filter, primary extended life.....	EAF5153
filter, safety radial seal.....	P609518*

* shipped initially with air cleaner

G290052, G290053, G290057

cover	P603716
cover chain	P017281
chain connector	P017283
dust cup (3 on unit)	P158089
dust cup gasket (3 on unit)	P017804
dust cup clamp (3 on unit).....	P100808
dust cup vacuator valve (3 on unit).....	P103198
body gasket strips (two, long).....	P115096
body gasket strips (two, short)	P115098
rain shroud, right side	P119874
rain shroud, front	P119877
rain shroud, left side.....	P119875
lower body assembly (G290052,53) ..	P118552
lower body assembly (G290057)	P115110
filter, primary radial seal.....	P608306*
filter, primary extended life.....	EAF5152
filter, safety radial seal.....	P608305*

G290055 (longer upper body)

cover	P603716
cover chain	P017281
chain connector	P017283
dust cup (3 on unit)	P158089
dust cup gasket (3 on unit)	P017804
dust cup clamp (3 on unit).....	P100808
dust cup vacuator valve (3 on unit).....	P103198
body gasket strips (two, long).....	P115096
body gasket strips (two, short)	P603504
rain shroud, right side	P610776
rain shroud, front	P119877
rain shroud, left side.....	P610777
lower body assembly.....	P609508
filter, primary radial seal.....	P609519*
filter, primary extended life.....	EAF5153
filter, safety radial seal.....	P609518*

*Upgrade from SRG
housings to new SSG!*

SRG Model	SSG Model
G200008	G200087
G200013	G200086
G290000	G290057
G290023	G290052
G290012	G290053

Donaldson®
Endurance

For extended air filter
life, try our
Donaldson
Endurance Air Filters
with
Ultra-Web®
Nanofiber
Technology

