

Convenient DuraLite Disposables

Rugged Air Cleaners for Small and/or High Pulsation Gas & Diesel Engines

Donaldson's DuraLite Air Cleaners are tough, non-metallic, lightweight, self-supporting and completely disposable. They are also easy to install, durable, and reliable.

They are designed to function well under high and severe pulsation conditions found in many applications, especially two- and three-cylinder engines. Vibration-resistant media is potted into molded housings of rugged ABS plastic – so they don't fall apart as other designs might.

Applications

- Can be mounted vertically or horizontally
- Gas and diesel engines in light to medium dust conditions
- Powered vehicles & equipment
- Mobile engines
 - Stepvans
 - Recreational vehicles
 - Lawn & garden tractors
- Stationary engines
 - Air compressors
 - Refrigeration units
 - Material handling equipment pumps
 - Gen sets
 - Welding equipment
- Marine engines
 - Propulsion units
 - Gen sets
- Provides variety of airflow volumes to engine: from 42 to 2118 cfm
- Temperature tolerance:
 - 180°F/83°C continuous
 - 220°F/105°C intermittent



Donaldson recommends the use of a high torque hose clamp (up to 150 lbs.-in) for DuraLite air cleaners. This clamp eliminates the need for double clamping – order one for each DuraLite air cleaner. See page 98 for more information.



DuraLite™ Air Cleaners – sturdy, one-piece, disposable – are designed to withstand the high pulsation of small engines such as the ones shown here. They are easy to maintain because there are no service parts! When the filter is full, simply throw it away.



Air Cleaner Features

- No serviceable parts! Air cleaner housing and filter are one unit!
- Designed to withstand severe intake pulsation
- Economical replacement cost
- Self-supporting, sturdy
- Very reliable: only one critical seal
- Lightweight and compact in size
- Non-metallic (except B085008 which is galvanized steel), non-corrosive... ideal for marine applications
- Completely disposable...acceptable for normal trash pick-up (DuraLite should not be incinerated)
- Easily installed and maintained
- Minimal removal clearance needed: only 1.5"
- Three airflow styles available to fit virtually any engine intake configuration
- Various media available for specific applications: high pulsation, high humidity, etc.

LIGHT DUST

When spec'ing an Air Cleaner . . .

Determine the airflow requirements of your engine, then find the corresponding cfm airflow in the table at right. The restriction numbers (shown in inches of water) indicate the approximate initial restriction of each model air cleaner at that cfm. If there are two air cleaner models that fit your parameters, choosing the one with the lowest restriction will provide longest filter service life. When calculating total initial restriction of the entire air intake system, include the restriction caused by ducting, elbows, pre-cleaners, etc.

ECB DuraLite



Airflow Pattern "B"

Air in the side, out the end

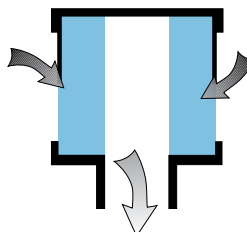

ECC DuraLite



Airflow Pattern "C"

Air in the end, out the same end

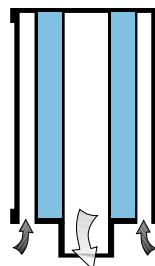

ECD DuraLite



Airflow Pattern "D"

Air in the end, out the opposite end



ECB Initial Airflow Restriction

4"	CFM @ "H2O		Air Cleaner Model
	6"	8"	
175	250	300	B085008
275	335	390	B085001
275	335	390	B085048
280	400	470	B085011
280	400	470	B085046
380	440	480	B105020
400	580	710	B105002
450	590	680	B105006
700	882	1024	B125011
800	1060	1250	B125005
830	1110	1295	B125003
970	1215	1412	B085056
1060	1305	1500	B120439
1550	1836	2118	B120376

ECC Initial Airflow Restriction

4"	CFM @ "H2O		Air Cleaner Model
	6"	8"	
42	55	64	C045001
55	70	82	C045002
64	82	94	C055003
70	90	106	C055002
95	111	140	C065001
108	137	162	C065002
112	145	170	C085001
115	147	190	C065015
115	150	175	C085005
120	150	175	C065003
130	165	188	C085002
135	170	195	C085006
135	170	195	C085043
150	180	215	C085003
170	205	245	C085004
170	205	245	C085041
325	400	480	C105003
352	400	480	C105028
400	500	620	C105004
400	500	620	C105017
485	620	760	C125004

ECD Initial Airflow Restriction

4"	CFM @ "H2O		Air Cleaner Model
	6"	8"	
44	56	65	D045003
50	64	75	D045004
78	97	115	D055004
102	127	152	D065003
125	155	185	D065008

Note: D065008 has inlet holes on both ends of filter

ECB DuraLite™ Specifications

Air Cleaner Models	Body Diameter (A)		Outlet Diameter (C)		Length (D)		Outlet Length (F)		Media Type	Weight	
	in	mm	in	mm	in	mm	in	mm		lbs	kg
B085001	8.50	216	3.00	76	11.00	279	1.38	35	A	4.2	1.9
B085008 ¹	8.75	222	3.00	76	8.50	216	1.38	35	A	5.5	2.5
B085011	8.50	216	4.00	102	11.00	279	1.38	35	A	4.2	1.9
B085046	8.50	216	4.00	102	11.00	279	1.38	35	B	4.2	1.9
B085048	8.50	216	3.00	76	11.00	279	1.38	35	B	4.2	1.9
B085056	7.72	196	5.67	144	11.02	280	1.38	35	B	3.2	1.5
B105002	10.50	267	5.00	127	15.00	381	1.38	35	C	5.9	2.7
B105006	10.50	267	4.00	102	10.50	267	1.38	35	A	5.2	2.4
B105020	10.50	267	4.00	102	10.50	267	1.38	35	B	3.6	1.6
B120376	12.5	318	7.8	198	15.75	400	1.89	48	D	8.0	3.6
B125011	12.5	318	5.0	127	9.0	229	1.38	35	D	6.6	3.0
B120439	12.5	318	7.78	197	15.75	400	1.57	40	A	3.5	1.6
B125003	12.50	318	6.00	152	15.00	381	1.38	35	C	7.1	3.2
B125005	12.50	318	5.50	140	9.00	229	1.38	35	D	5.0	2.3

ECC DuraLite™ Specifications

Air Cleaner Models	Body Diameter (A)		Outlet Diameter (C)		Length (D)		Outlet Length (F)		Media Type	Weight	
	in	mm	in	mm	in	mm	in	mm		lbs	kg
C045001	4.50	114	1.50	38	4.50	114	1.38	35	C	0.6	0.27
C045002	4.50	114	1.50	38	8.00	203	1.38	35	C	0.9	0.40
C055002	5.50	140	1.75	44	7.00	178	1.38	35	C	1.0	0.45
C055003	5.50	140	1.75	44	4.00	102	1.38	35	C	1.0	0.45
C065001	6.50	165	2.00	51	4.00	102	1.38	35	C	0.8	0.36
C065002	6.50	165	2.00	51	7.50	191	1.38	35	C	1.3	0.60
C065003	6.50	165	2.25	57	5.00	127	1.38	35	C	1.0	0.45
C065015	6.50	165	2.00	61	9.00	229	1.38	35	D	2.0	0.90
C085001	8.50	216	2.50	64	4.00	102	1.38	35	C	1.4	0.64
C085002	8.50	216	2.50	64	6.50	165	1.38	35	C	2.2	1.0
C085003	8.50	216	3.00	76	5.00	127	1.38	35	C	2.2	1.0
C085004	8.50	216	3.00	76	9.50	241	1.38	35	C	3.0	1.4
C085005	8.50	216	2.50	64	5.00	127	1.38	35	C	2.2	1.0
C085006	8.50	216	2.50	64	9.50	241	1.38	35	C	3.0	1.4
C085041 ³	8.50	216	3.00	76	9.50	241	1.38	35	C	3.0	1.4
C085043 ³	8.50	216	2.50	64	9.50	241	1.38	35	C	3.0	1.4
C105003	10.50	267	4.00	102	6.00	152	1.38	35	A	2.3	1.0
C105004	10.50	267	4.00	102	10.50	267	1.38	35	A	3.6	1.6
C105017 ³	10.50	267	4.00	102	10.50	267	1.38	35	A	3.6	1.6
C105028 ³	10.5	267	4.0	102	6.0	152	1.38	35	A	3.4	1.5
C125004	12.50	318	5.00	127	11.00	279	1.38	35	A	5.8	2.6

ECD DuraLite™ Specifications

Air Cleaner Models	Body Diameter (A)		Outlet Diameter (C)		Length (D)		Outlet Length (F)		Media Type	Weight	
	in	mm	in	mm	in	mm	in	mm		lbs	kg
D045003	4.50	114	1.50	38	4.50	114	1.38	35	C	0.6	0.27
D045004	4.50	114	1.50	38	6.00	152	1.38	35	C	0.8	0.36
D055004	5.50	140	1.75	44	7.00	178	1.38	35	C	1.0	0.45
D065003	6.50	165	2.00	51	4.00	102	1.38	35	C	0.8	0.36
D065008 ⁴	6.50	165	2.00	51	9.00	229	1.38	35	D	1.5	0.68

Media Types:

- A = Standard media
- B = Treated to withstand higher humidity...most often used in marine applications
- C = Reinforced to withstand higher pulsation applications
- D = Designed for higher airflow/low dust applications... should NOT be used for normal engine operating environments

Specification Illustrations

ECB DuraLite

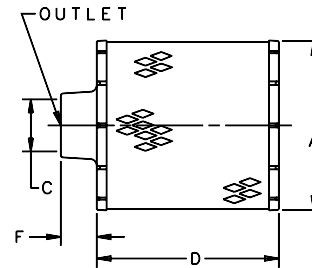

ECC DuraLite

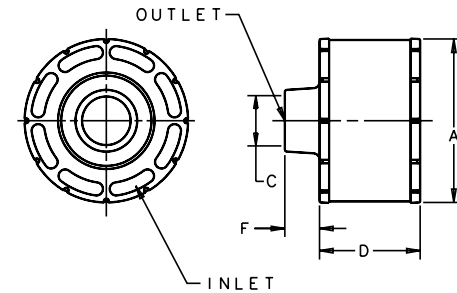

ECD DuraLite

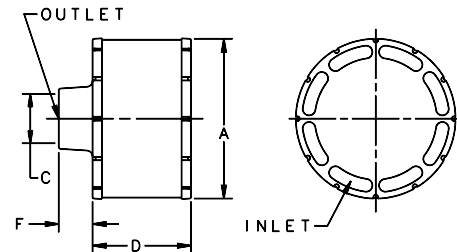

Note: D065008 has inlet holes at both ends of filter

Specifications Notes:

- 1 - Body is galvanized steel with 4" (254mm) dia. inlet on side
- 2 - Body is plastic with 4" (254mm) dia. inlet on side
- 3 - Screen inlet deters rodent infestation
- 4 - Has inlet holes at both ends of filter

LIGHT DUST

Installation Instructions

Installation

DuraLite air cleaners can be mounted in two ways:

1. **Direct Mount:** mounted directly on the intake manifold.
2. **Remote Mount:** mounted away from engine and connected to engine with inlet piping.

Installation Tips

- Engage outlet neck of the DuraLite over intake piping for a full 1½" to insure a secure, lasting seal.
- Tighten clamp around outlet neck to 60 lbs-in minimum. A Donaldson high torque hose clamp is recommended.
- On remote mount style, avoid crushing the body with body clamps. A snug fit is best, and body clamps are not always required.
- Keep away from engine manifold and other very hot components (DuraLite is rated at 180°F/83°C maximum sustained temperature).
- Keep away from battery acids, brake fluid, and other caustic fluids.

Direct Mount

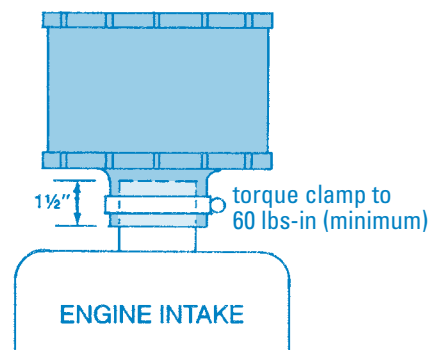

Remote Mount

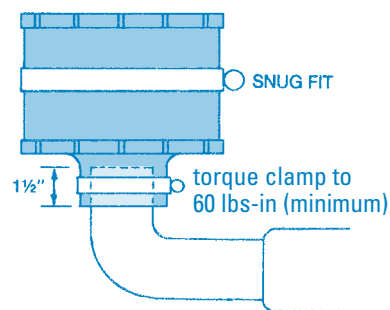

Service Recommendations

Servicing Intervals

Choose either of two types:

- **Scheduled maintenance.** DuraLite service intervals can be integrated into any existing maintenance program.
- **Restriction Maintenance.** This method offers the most accurate filter maintenance program, delivering maximum filter life at 99.9% efficiency, less machine downtime, and reduced maintenance costs.
- Washing, cleaning or servicing the filter in any way voids the warranty.

Service Indicator Location

For proper restriction readings, a restriction fitting tap must be located between the engine intake and DuraLite outlet neck. The tap should be located in a straight section of the intake pipe at least one pipe diameter away from the manifold or any bends, elbows or reducers.

Servicing Tips

- Do NOT judge the filter on the basis of visual inspection! If it's doing its job, it should look dirty. DuraLite filter life is longer than you may think. Change the filter only when restriction readings indicate.
- Do NOT leave the inlet ducting exposed any longer than necessary (a few minutes) during service.

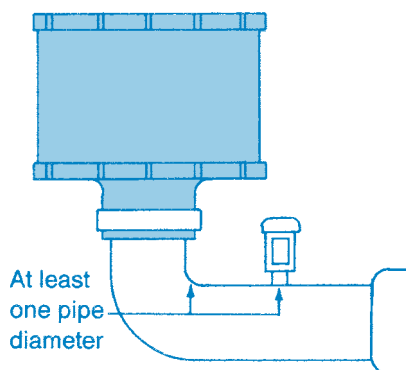

Disposal

Normal trash pick up is acceptable – never burn.